



PET THOR

hammer mill for fine grinding



Via Porziuncola, 28
06081 Assisi (PG)



075 8043623



info@mial.com



www.mial.com



PET THOR: Hammer mill for fine grinding



The PET THOR Hammer Mill is designed for the fine grinding of Pet Food and Fish Food.

POWER: up to 250 kW

SPEED: 2800 RPM

SCREENS: UP TO 2 mq

The PET THOR Hammer Mill has an innovative system for replacing the hammers which considerably speeds up its maintenance, eliminating the possibility of errors and requiring only one operator.

The replacement of the screen is carried out quickly and easily thanks to the large sliding doors and to the release system of the press grid with return springs that support the opening for the safety of the operators.

The accurate design of the internal geometries and the balancing of the rotor significantly reduce noise emissions and minimize vibrations.

The wide range of versions available means that it can be used in both medium and large plants.



CARATTERISTICHE E VANTAGGI

Features and Benefits

- 1 Unique hammer change system.
- 2 High rotation speed which means greater grinding efficiency.
- 3 Easy replacement of the rotor for easy maintenance and to reduce machine downtime.
- 4 Double rotation direction to optimize the wear of the hammers and screens.



- 5 Fast coupling and release system of the press grid with spring balancing for a quick and easy replacement.

- 6 Power supply with gravimetric and magnetic separation for a uniform dosing.

- 7 Easily removable high-capacity waste container

- 8 Heat-treated special steel hammers with 4 usable edges.

- 9 Optimization of friction in order to guarantee low energy consumption.

- 10 Armor made of wear-resistant and easy-to-replace materials. Reusable up to 4 times.



DISEGNO TECNICO

Typical Layout

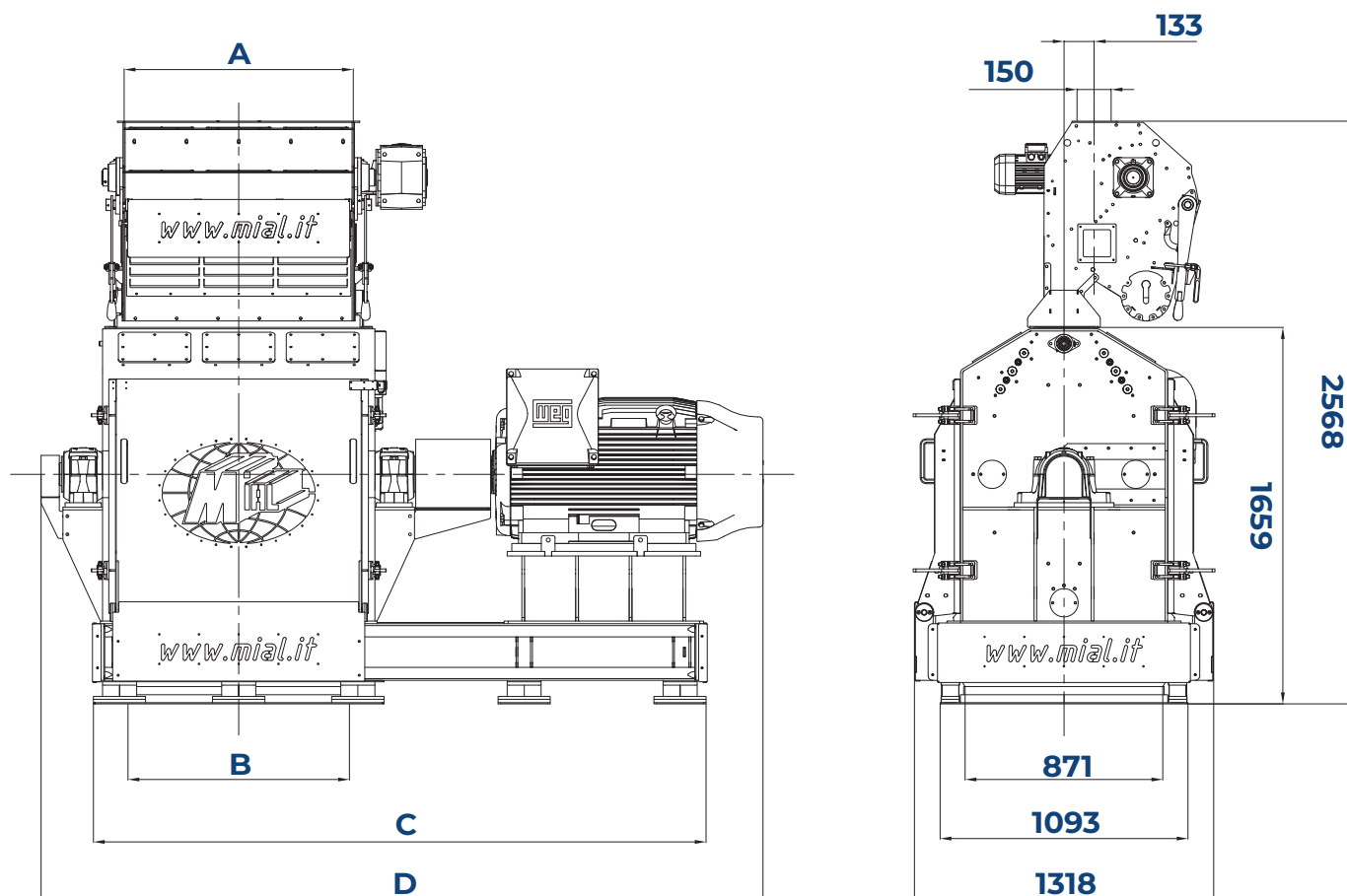

MODEL	POWER (KW)	SCREEN SURFACE(MQ)	NUMBER OF HAMMERS	A (mm)	B (mm)	C (mm)	D (mm)
PET THOR 2000	250÷315	2	200	1200	976	2700	3180
PET THOR 1600	200÷250	1,6	160	808	772	2400	2880
PET THOR 1200	132÷200	1,2	120	604	568	2086	2566
PET THOR 800	90÷132	0,8	80	400	364	1721	2200

